

Key Information

Shipping boats is an entitlement outlined in the Joint Travel Regulation (JTR).

If you are using a boat as your **primary residence** it can be moved in lieu of Household Goods (HHG). Discuss with your counselor on authorized reimbursable expenses based on how you are moving your residence.

Electing the government to move your boat can be costly; be sure you understand all requirements and costs before initiating movement. Your local Transportation Office will provide you with **estimated** shipping charges. Exact costs will not be known until final shipping charges are submitted by the vendor.

Responsibility: Provide dimensions (Length, Width, Height) for the boat and trailer separately. Ensure the boat is prepared for shipment. (ref DTR 412). Pay all accessorial service charges, including special packing, crating and handling costs. Remove pilferable items, clothing, televisions, skis, and similar items. Lower or remove all antennas, masts, fishing/trolling poles, and outriggers. Ensure the boat is ready for the Transportation Service Provider (TSP) on the agreed pickup date. The TSP can charge you for attempted pickup if the boat is not ready on agreed upon date to pickup.

Please see your local transportation office for assistance or additional guidance.

Measurement

EXACT MEASUREMENTS REQUIRED

Boats over 14' can move in a van when the TSP agrees to move the boat over 14' with or without the member's HHGs.

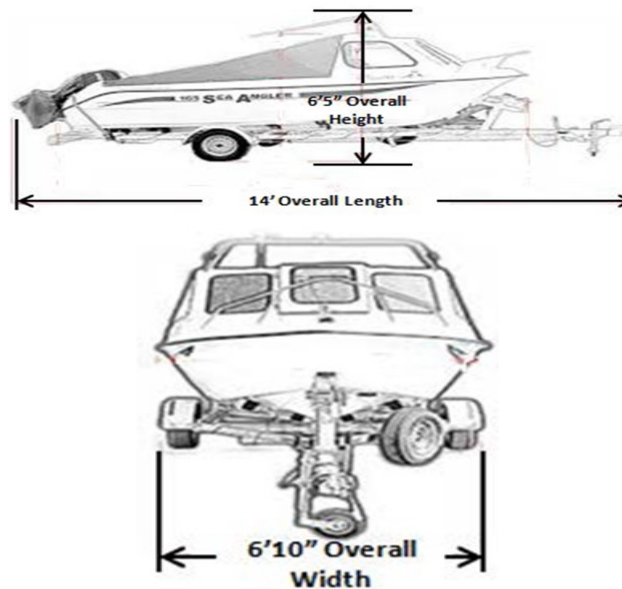

HELPFUL LINKS

"It's Your Move" Pamphlet

https://www.move.mil/dod/before_you_begin/prepare_for_your_move.cfm

Joint Travel Regulation (JTR)

(entitlement)

www.defensetravel.dod.mil/site/travelreg.cfm

Defense Transportation Regulation (DTR)

Chapter 412 (how accomplished)

www.ustranscom.mil/dtr/dtrp4.cfm

Move.mil

<https://www.move.mil>



MOVEMENT OF BOATS



Navy Assistance

Email: householdgoods@navy.mil

Customer HHG website:

<https://www.navsup.navy.mil/household>

Customer Contact Center:

855-HHG-MOVE (855-444-6683)

Social media links:

www.facebook.com/navyhhg

www.pinterest.com/navyhhg

www.youtube.com/navyhhg

www.twitter.com/navyhhg

Marine Corps Assistance

Email: usmcpersonalproperty@usmc.mil

Phone: 703-695-7765 DSN: 225-7765,

Facebook:

www.facebook.com/usmchouseholdgoods

Air Force Assistance

ppahg.ppec.customerservice@us.af.mil

Boat Definition

Boat dimensions equal to or less than the below may be shipped with your HHG shipment:

Length = 14 feet (168 inches)
Width = 6 feet 10 inches (82 inches)
Height = 6 feet 5 inches (77 inches)

“Boat” definition varies for military members and civilian employees.
(Ref JTR App A)

Military:

1. A boat/personal watercraft (include but not limited to: jet ski, canoe, skiff, dinghy, scull, kayak, rowboat, sailboat, outboard/inboard motorboat) with or without the associated trailer, **size restriction does not apply**.
2. Boats with dimensions greater than above can be moved using other shipping methods. Talk to your local counselor for options.

Civilian Employee:

1. A boat/personal watercraft (including but not limited to: jet ski, canoe, skiff, dinghy, scull, kayak, rowboat, sailboat, outboard/inboard motorboat) of **reasonable size that can fit in a moving van**, with or without their associated trailer.
2. Employee are authorized to move a boat with or without their associated trailer that exceed 14 feet in length, but 18 feet or less in length using the One-Time-Only (OTO) program.

Maximum size for a moving van is:
18' L X 6' 10" W X 6' 5" H

Weight Additives

When a boat is stored a weight additive (net item weight + charge for length of item = weight additive/billed) is applied against your authorized weight allowance.

Example:

Kayaks/Canoes over 14 feet 40 lbs/linear foot is **50 lbs + 450 weight additive = 600 lbs weight billed against your authorized weight allowance.**

Boat Movement

There are many ways to move boats

Haul-Away: The movement of a boat with or without a trailer by a commercial TSP with specialized equipment used to transport boats on cradles, racks, or flatbeds from an origin to a destination. This service is normally for a large boat without a trailer or a boat with non-roadworthy trailer. Boats without trailers can be picked up and delivered from/to a marina.

Tow-Away: The movement of a boat with trailer by a TSP towed with a self-contained power unit capable of being operated over the highways.

Personally Procured Move:

Customer makes all arrangements for move and pays for services rendered. Reimbursement for shipment is IAW JTR requirements. Military members are authorized advanced operating allowance IAW JTR/Service regulations

Shipment of boats within the 48

states: Generally tow-away or haul-away services are used and are scheduled with the shipment of your HHGs. Boats and their associated trailers of any size may be shipped in a standard HHG move **if TSP agrees.**

Shipment of boats to overseas locations, to include Alaska:

Boat/trailer combination within the dimensions above will be shipped with your HHGs. If the dimensions are greater than those above it will be processed using the OTO program.

Storage

Military members and civilian employees have the option to store their boat IAW the JTR. The definition and size limitations identified under the movement sections also apply for storage.

When storing a boat, the storage facility is authorized to bill for weight additive. Weight additive is for larger items which utilize warehouse space typically designated for storage vaults.

It is your responsibility to prepare the boat/personal watercraft for storage (e.g., cleaning the boat/watercraft, draining the fuel, disconnecting the battery, remove drain plugs).

Remember, if the government has stored your boat and then you request the government to release and procure shipment, you may incur excess cost.

Excess Cost

When determining out of pocket expenses the government utilizes your Max Government Obligation (MGO) to determine excess cost. The MGO is calculated using your max weight entitlement, regardless of weight shipped, to and from your authorized points on the orders. If you exceed your MGO, including any weight additives you pay for the excess costs.

If you elect to ship your boat overseas and there were no excess or minimal excess charges going over, there may still be excess charges coming back.